



FEDHARMONY# 41854

24 Sep 2024

Alyssa Webb

erin.a.webb@wv.gov

304-926-0499

Subject: **Agency Request for Quote (ARFQ)**

Reference: Solicitation # **ARFQ-0608-DCR250000020-1**

Dear Ms. Webb,

In response to Solicitation # **ARFQ-0608-DCR250000020-1**, Global Enterprise, Inc. is pleased to submit the enclosed open market quote for the **Agency Request for Quote (ARFQ)**. The quote accounts for all labor, tools, equipment, materials, shipping, and project management needed to achieve the prescribed requirements. We reserve the right to impose a surcharge on credit card purchases that is not greater than our cost of acceptance. We state acceptance of all other solicitation terms, conditions, and provisions.

Our team has substantial past performance and experience delivering comparable projects. Our past successes and experience provide assurance for your organization that the final product will be delivered on time and as specified in the requirements.

We are offering a Snorkel S3219 Plus to meet stated requirements. Current production estimates a 90-120 day delivery ARO. Please reference the Compliance Matrix and Product Literature within this submission for exact conformance. Additional information is available upon request.

You may reach me at 703-624-1206.

Respectfully,

Scott Smith

President

Global Enterprise, Inc.

Requests@Fedharmony.com

(703) 624-1206

DUNS: 02-321-3949

UEI: L3P3MXXX2W59

CAGE: 644N7

Business Size: Small Business



Technical and Management Approach

Solicitation Number: ARFQ-0608-DCR250000020-1

Project Name: Agency Request for Quote (ARFQ)

FEDHARMONY#41854

Prepared For

Alyssa Webb

erin.a.webb@wv.gov

304-926-0499

Prepared By

Global Enterprise, Inc.

DBA Fedharmony

104 Tech Park Drive

Suite 11

Cambridge, MD 21613

Prime Contractor

Mr. Scott Smith

President

Global Enterprise, Inc.

3521 Goddard Way Ste. 400

Alexandria, VA 22304

Mobile: 703-624-1206

Email: Orders@fedharmony.com

Program Management Office

Mr. Keith Vandemark

Orders Manager

Fedharmony

104 Tech Park Drive, Suite 11

Cambridge, MD 21613

Mobile: 703-826-4166

Email: Orders@fedharmony.com

This data, furnished in connection with Solicitation # **ARFQ-0608-DCR250000020-1** shall not be disclosed outside the Government and shall not be duplicated, used, or disclosed in whole or in part for any purpose other than to evaluate the proposal; provided that if a contract is awarded to this Offeror as a result of or in connection with the submission of this data, the Government shall have the right to duplicate, use, or disclose the data to the extent provided in the contract. This restriction does not limit the Government's right to use information contained in the data if it is obtained from another source without restriction. The data subject to this restriction is contained in all sheets except page ii (Table of Contents).



TECHNICAL APPROACH

Global Enterprise, Inc. and Fedharmony are both S Corporations wholly owned by Scott Smith. For small business concerns they are distinct entities, but effectively they operate as a single company, with Scott Smith as President and owner of both. Global is a dealer/distributor of equipment using GS30F-040BA and GS07F-248BA. Automotive and Law Enforcement.

Fedharmony provides turn-key Business Development, Systems Engineering, Project Management, Contracts Administration, and Customer Service services. Fedharmony's primary 'customer' is Global, but also supports other GSA contract holders and 'sister' companies of Global/Fedharmony/Scott Smith (Worldwide Enterprise, Inc., Products on GSA, Inc., American Enterprises, Inc.)

Fedharmony identifies a qualified manufacturer and outsources the production of the equipment according to the government specifications. Fedharmony's Systems Engineering understands a wide array of equipment manufacturing, and most importantly, government expectations, for workmanship, functionality, and acceptance testing.

Fedharmony's approach to outsourced manufacturing is consistent with the industry practice of private label manufacturing, and is a core competency of Mr. Smith, who previously held positions of Director of Total Quality Management and Director of Manufacturing for \$100M+/year firms. Furthermore, Fedharmony's warranty complements the typical manufacturer warranty, with service provided by a local Place of Performance authorized service agent.

Snorkel



Not only do our scissor and boom lifts raise fellow human beings high into the air, they must also safely bring them back down. And they need to do both safely and smoothly, again and again. So, our machines are engineered beyond the industry norm, to an uncommon level of safety and durability. But they're also engineered to be simple — simple to operate and simple to maintain. Which is somewhat uncommon.

Commercial Item Matrix

Agency Request for Quote (ARFQ) DCR2500000020

Item No.	Description	Compliance	Compliance Comments
1.	Delivery Date: 10 Days	N	90 - 120 Days ARO
2.	Delivery to: White Sulphur Springs, WV 24986.	Y	
3.	QTY: (1)	Y	
4.	GENERAL REQUIREMENTS:		
5.	Vendor must provide a quantity of one (1) Genie GS – 1930, EDrive, 110 V GS1930E1CE0001 New Lift or Equal with the following features:	Y	Snorkel S3219 Plus
6.	Must have a working height maximum of 25 feet 3 inches in an indoor space	Y	25'
7.	Must have a working height maximum of 20 feet 8 inches in an outdoor space.	Y	25'
8.	Must have a machine height at folding rails stowed of 7 feet 1 inches with a machine height at rails lowered stowed with 5 feet 11 inches. Must have a stowed machine length at 6 feet and a stowed extended machine length at 8 feet 11 inches	Y/N	6'6.75" All Time. No folded Rails
11.	Must have a machine minimum width of 2 feet 6.2 inches with a machine wheelbase minimum of 4 feet 4 inches.	Y	32" Wide
12.	Must have a minimum ground clearance for machine center with pothole guards retracted of 3.2 inches. Must have a minimum ground clearance for the machine with pothole guards deployed of 0.9 inches.	N	2.63"
13.	Must have a platform with Folding rails. Half-height swing gate	N/A	No Folded Rails needed. Unit has swing door
14.	Slide out extension deck	Y	

15.	power to platform – no RCBO, AC power to platform, descent – tilt and motion alarm	Y	
16.	diamond plat platform deck	Y	
17.	dual led flashing beacons	N	Single Strobe
18.	electric horn	Y	
19.	lanyard attachment points	Y	
20.	platform control guard (PCON)		Genie Specific
21.	platform load sense system	Y	
22.	proportional drive and lift	Y	
23.	and SmartLink dual zone control system.		Genie Specific
24.	Must have a platform height max indoor of 19 feet 3 inches	Y	19'
25.	platform height max outdoor of 14 feet 8 inches	Exceeds	
26.	platform height stowed of 3 feet 5 inches	Y	
27.	platform length outside 5 feet 5 inches	Y	6'
28.	platform length outside extended 8 feet 5 inches	Y	9' Extended
29.	slide-out platform extension deck length 2 feet 11.8 inches	Y	36"

30.	platform width outside guardrail height 3 feet 7 inches, and platform width outside toeboard height 6 inches.	Y	
31.	A minimum of the standard power for Genie GS-1930 Models as standard FLA flooded lead acid batteries, 24V DC (4x6V 210 Ah), and rear recessed charger receptacle with a hydraulic tank capacity (E-Drive) of 1 gallon.	Y	Lithium Powered
32.	A minimum chassis with auxiliary platform lowering, drivable at full height	Y	
33.	dual front wheel sealed AC electric drive motors (E-Drive), lift tools spill guard (E-Drive)	Y	
34.	dual wheel multi-disc brakes, electric brake release (EDrive)	Y	
35.	on board diagnostic system with battery charge indicator	Y	
36.	pothole protection, side and rear fork pockets	Y	
37.	solid non-marking tires, tech pro link connector, and tiedown and lifting points.	Y	Y – Non-Marking Tires Y – Tiedown/Lifting Points N – Tech Pro Link Connector (Genie Specific)
38.	Must have a minimum of maximum platform occupancy in and out of 2/1	Y	
39.	lift capacity of 500 pounds	Exceeds	600 pounds
40.	lift capacity with extension deck extended of 250 pounds	Y	
41.	maximum platform drive height of 19 feet and 3 inches	N	Full height 19'

42.	drive speed stowed at 2.5 mph	N	2.0 MPH
43.	drive speed raised at 0.5 mph	N	0.4 MPH
44.	gradeability stowed at 25%, turning radius inside and outside of 0/5 feet 1 inch	Y	
45.	lifting speed raise 26 seconds	Y	
46.	lifting speed lower 22 seconds	Y	
47.	tilt sensor activation front to back of 3 degrees and 1.5 degrees for tilt sensor activation side to side	Y	
48.	tires solid non-marking for 12 x 4.5 inches.	N	12.7"
49.	Must have a minimum weight of 3,209 pounds, weight maximum of 3,354 pounds with adding all possible options	Exceeds	2,900 lbs
50.	tire load maximum 1,483 pounds, tire contact pressure 165 psi, occupied floor pressure 287 psf.	Y	
51.	Must have a minimum of sound pressure level with ground workstation < 70 dBA, sound pressure level with platform workstation < 70 dBa, and vibrations of <8 feet 2 inches/s ²	Y	
52.	Alternative 'or Equal' Submission: A Vendor submitting an alternate brand item must provide alternate brand information and documentation with their bid response, i.e., brochures, pamphlets, product specs, MSDS sheets, etc.	Y	

S3219 PLUS

LITHIUM ELECTRIC SCISSOR LIFT

 **Fedharmony**
Suppliers to Buyers™

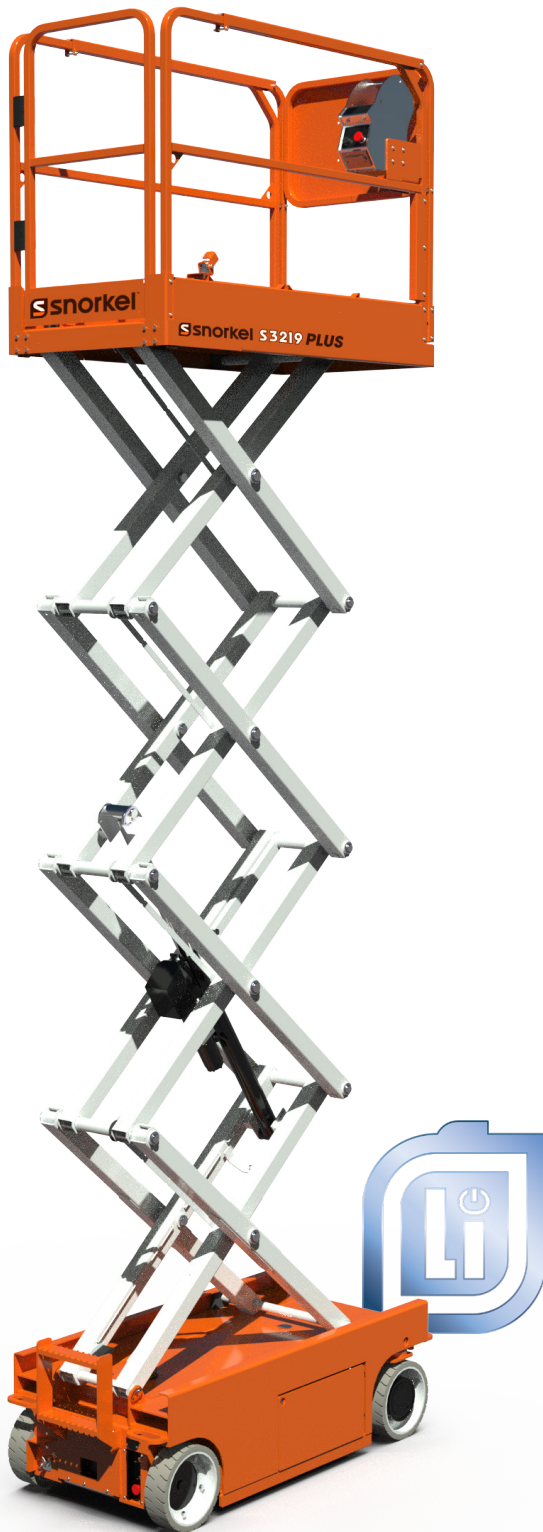

- Electrically operated
- No hydraulic hoses
- Low step-in platform height
- NO FOLDING RAILS
- Fits standard doorways
- Large non-marking tires
- Indoor/Outdoor operation
- 5-year battery warranty

 **snorkel**™
www.snorkellifts.com

ELECTRIC DRIVE SLAB SCISSOR LIFT

S3219 PLUS

DIMENSIONS

Max. Working Height	25 ft (7.62m)
Max. Platform Height (A)	19 ft (5.79m)
Platform Size (Stowed)	31.5 in x 69 in (0.8m x 1.75m)
Platform Size (Extended)	31.5 in x 105 in (0.8m x 2.66m)
Deck Extension Length	36 in (0.91m)
Overall Length (C)	72 in (1.8m)
Overall Width (D)	32 in (0.81m)
Stowed Height (B)	78.75 in (2.0m)
Ground Clearance (Stowed)	2.63 in (0.06m)

PERFORMANCE

Platform Capacity (SWL)	600 lbs (272.1kg)
Max. Wind Speed	28 mph (45kph)
Max. Drive Height	19 ft (5.79m)
Max. Drive Speed (Stowed)	2.0 mph (4kph)
Max. Drive Speed (Elevated)	0.4 mph (0.8kph)
Raise/Lower Time	35/20 sec
Gradeability	25%
Max. Operation Slope (side-to-side)	1.5 degrees
Max. Operation Slope (front-to-back)	4 degrees
Inside Turning Radius	5 in (0.12m)
Outside Turning Radius	58 in (1.47m)
Tires	12.7 in (0.32m)
Controls	Proportional
Drive System	Dual DC Motors
Parking Brake	2-wheel, spring applied

POWER

Power Source	Two (2) 24V 60Ah Lithium Batteries
Charger	20A

WEIGHT

Weight	2,900 lbs (1315.4kg)
--------	----------------------

TURNING RADIUS

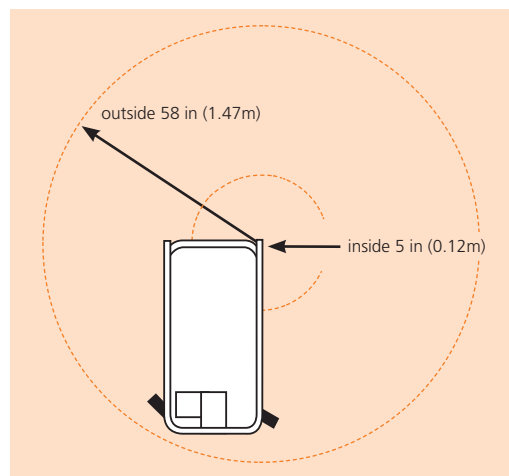

**TAKE A
TOUR**

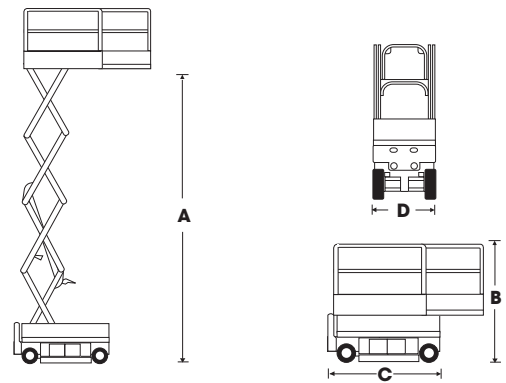

STANDARD FEATURES

- 100% Operation 2 person indoor, 1 person outdoor
- Lithium battery operated scissor lift
- No hydraulic hoses
- Fits standard doorway *without* folding rails
- Roll-out-deck with dual locks
- Non-marking tires—largest wheels/tires in class
- Heavy-duty spindles/steering
- Heavy-duty fixed control box
- Descent and all-motion alarms
- ANSI A92.20 compliant
- Proportional control, all functions
- Platform overload protection
- 110 V (15 amp) power to platform
- On-board diagnostics, hour meter, battery meter
- Automatic integrated battery charger
- Manual safety lowering system
- Flashing amber strobe
- Forklift pockets, crane lifting points
- Lanyard attachment points
- Swing-out service trays
- 2-year parts & labor warranty
- 5-year lithium battery & structural warranty

snorkel

Fedharmony
Suppliers to Buyers™

www.snorkellifts.com



MANAGEMENT

Fedharmony, a division of Global Enterprises, Inc. (FH) will provide the program/project management role. Fedharmony will provide the program/project management role. In this role, Fedharmony will be the primary interface and advocate for this project to ensure that the project is completed on schedule, within approved cost, to specification and exceeds expectations. Fedharmony's program/project management, contract management, manufacturing experience and teaming portfolio provide a special ingredient to ensure success.

PROGRAM MANAGEMENT

Strong program management and a good evaluation and control system are paramount in containing program cost and maintaining schedule. To facilitate the control process, FH will establish a project base line plan through the development of an integrated master schedule (IMS). The IMS will establish the timing required to perform each task and provide the tool necessary to maintain schedule and measure progress. The establishment of a weekly status report will provide the PM with the performance data necessary to measure performance against the established baseline. The PM will monitor the overall program performance and identify potential schedule or cost issues which can then be analyzed, using EVM techniques, to determine an appropriate course of action. If during the monitoring of the program performance cost becomes a concern, the EVM provides valuable tools that will allow the PM to measure and analyze material cost against actual and estimated actual cost to identify potential cost overruns and determine an appropriate course of action.

KEY PERSONNEL

Scott Smith, PMP, President, Fedharmony

Scott Smith is president of Fedharmony, a boutique firm specializing in bringing innovative solutions to small businesses and federal, state, and local governments. His unique capability is a deep understanding of industry side of business as well as the complexities of government contracting. Highlights of his government support include authoring the American Red Cross's business plan for Coord Blood Banking, development of the Enterprise Architecture for the 2010 Census' hand-held devices and initiating the national digitization effort for the General Services Administration (GSA). Prior to federal contracting support, he spent a decade as a hands-on engineer and manager in the international apparel manufacturing industry. In addition to building factories for the likes of Rawlings Sporting Goods and Oxford Industries throughout Central America and the Caribbean he also managed full production and product development. He is a certified Project Management Professional and holds a BS in Industrial Engineering.

REQUEST FOR QUOTATION

ARFQ 0608 DCR2500000020 Electric Slab Scissor Lifts for Anthony Correctional Center and Jail

SPECIFICATIONS

1. **PURPOSE AND SCOPE:** The West Virginia Department of Homeland Security - Division of Administrative Services (DAS) is soliciting bids on behalf of the West Virginia Division of Corrections and Rehabilitation (DCR) for Anthony Correctional Center and Jail to establish a contract for one time purchase of one Electric Slab Scissor Lift. The facility is located at 313 Anthony Center Drive, White Sulphur Springs, WV 24986.
2. **DEFINITIONS:** Definitions can be found in Section 2 of the General Terms and Conditions. The terms listed below shall have the meanings assigned to them as follows:
 - 2.1 **“Business Hours”** means Monday – Friday 8:00 AM to 5:00 PM EST excluding weekends and Federal and State holidays, which are as follows:
 - New Year’s Day (January 1)
 - Martin Luther King Day (Third Monday in January)
 - President’s Day (Third Monday in February)
 - Memorial Day (Last Monday in May)
 - Juneteenth (June 19)
 - West Virginia Day (June 20)
 - Independence Day (July 4)
 - Labor Day (First Monday in September)
 - Columbus Day (Second Monday in October)
 - Veterans Day (November 11)
 - Thanksgiving (Fourth Thursday in November)
 - Day After Thanksgiving (Fourth Friday in November)
 - Christmas Day (December 25)
 - 2.2 **“Contract Items”** means the list of items identified in Section 3.1 below and on the Pricing Page.
 - 2.3 **“Pricing Page”** means the schedule of prices, estimated order quantity, and totals contained in wvOASIS or attached hereto as Exhibit A and used to evaluate the Solicitation responses.
 - 2.4 **“Solicitation”** means the official notice of an opportunity to supply the State with goods or services that is published by the West Virginia Division of Administrative Services.

REQUEST FOR QUOTATION

ARFQ 0608 DCR2500000020 Electric Slab Scissor Lifts for Anthony Correctional Center and Jail

3. GENERAL REQUIREMENTS:

3.1 Contract Items and Mandatory Requirements: Vendor shall provide Agency with the Contract Item listed below on a one-time basis. Contract Items must meet or exceed the mandatory requirements as shown below.

3.1.1 Contract Item 1: Genie GS – 1930, e-Drive, 110 V GS1930E1CE0001 or Equal

3.1.1.1 Vendor must provide a quantity of one (1) Genie GS – 1930, E-Drive, 110 V GS1930E1CE0001 New Lift or Equal with the following features:

- 3.1.1.1.1** Must have a working height maximum of 25 feet 3 inches in an indoor space.
- 3.1.1.1.2** Must have a working height maximum of 20 feet 8 inches in an outdoor space.
- 3.1.1.1.3** Must have a machine height at folding rails stowed of 7 feet 1 inches with a machine height at rails lowered stowed with 5 feet 11 inches. Must have a stowed machine length at 6 feet and a stowed extended machine length at 8 feet 11 inches.
- 3.1.1.1.4** Must have a machine minimum width of 2 feet 6.2 inches with a machine wheelbase minimum of 4 feet 4 inches.
- 3.1.1.1.5** Must have a minimum ground clearance for machine center with pothole guards retracted of 3.2 inches. Must have a minimum ground clearance for the machine with pothole guards deployed of 0.9 inches.
- 3.1.1.1.6** Must have a platform with Folding rails, Half-height swing gate, Slide out extension deck, power to platform – no RCBO, AC power to platform, descent – tilt and motion alarm, diamond plat platform deck, dual led flashing beacons, electric horn, lanyard attachment points, platform control guard (PCON), platform load sense system, proportional drive and lift, and SmartLink dual zone control system. Must have a platform height max indoor of 19 feet 3 inches, platform height max outdoor of 14 feet 8 inches, platform height stowed of 3 feet 5 inches, platform length outside 5 feet 5 inches, platform length outside extended 8 feet 5 inches, slide-out platform extension deck length 2 feet 11.8 inches, platform width outside guardrail height 3 feet 7 inches, and platform width outside toeboard height 6 inches.
- 3.1.1.1.7** A minimum of the standard power for Genie GS-1930

REQUEST FOR QUOTATION

ARFQ 0608 DCR2500000020 Electric Slab Scissor Lifts for Anthony Correctional Center and Jail

- Models as standard FLA flooded lead acid batteries, 24V DC (4x6V 210 Ah), and rear recessed charger receptacle with a hydraulic tank capacity (E-Drive) of 1 gallon.
- 3.1.1.1.8** A minimum chassis with auxiliary platform lowering, drivable at full height, dual front wheel sealed AC electric drive motors (E-Drive), lift tools spill guard (E-Drive), dual wheel multi-disc brakes, electric brake release (E-Drive), on board diagnostic system with battery charge indicator, pothole protection, side and rear fork pockets, solid non-marking tires, tech pro link connector, and tie-down and lifting points.
- 3.1.1.1.9** Must have a minimum of maximum platform occupancy in and out of 2/1, lift capacity of 500 pounds, lift capacity with extension deck extended of 250 pounds, maximum platform drive height of 19 feet and 3 inches, drive speed stowed at 2.5 mph, drive speed raised at 0.5 mph, gradeability stowed at 25%, turning radius inside and outside of 0/5 feet 1 inch, lifting speed raise 26 seconds, lifting speed lower 22 seconds, tilt sensor activation front to back of 3 degrees and 1.5 degrees for tilt sensor activation side to side, and tires solid non-marking for 12 x 4.5 inches.
- 3.1.1.1.10** Must have a minimum weight of 3,209 pounds, weight maximum of 3,354 pounds with adding all possible options, tire load maximum 1,483 pounds, tire contact pressure 165 psi, occupied floor pressure 287 psf.
- 3.1.1.1.11** Must have a minimum of sound pressure level with ground workstation < 70 dBA, sound pressure level with platform workstation < 70 dBA, and vibrations of <8 feet 2 inches/s²
- 3.1.2 Workmanship:** Lift shall be free from defects that may impair operation, safety, emissions, and serviceability, or detract from appearance.

REQUEST FOR QUOTATION

ARFQ 0608 DCR250000020 Electric Slab Scissor Lifts for Anthony Correctional Center and Jail

3.1.3 Alternative 'or Equal' Submission

3.1.3.1 A Vendor submitting an alternate brand item must provide alternate brand information and documentation with their bid response, i.e., brochures, pamphlets, product specs, MSDS sheets, etc. Failure to submit substitute brand information and documentation will result in the bid being disqualified.

4. CONTRACT AWARD:

4.1 Contract Award: The Contract is intended to provide the Agency with a purchase price on all Contract Items. The Contract shall be awarded to the Vendor that provides the Contract Item meeting the required specifications for the lowest overall total cost as shown on the Pricing Page.

4.2 Pricing Page: Vendor must complete the Pricing Page by providing unit cost for each contract service. A Vendor must complete the Pricing Page in their entirety as failure to do so will result in Vendor's bids being disqualified. A no bid entered on the Pricing Page will result in Vendor's bid being disqualified.

Any product or service not on the Agency provided Pricing Page will not be allowable. The state cannot accept alternate pricing pages, failure to use Exhibit A - Pricing Page could lead to disqualification of Vendor's bid.

The Pricing Page contains a list of the Contract Items and estimated purchase volume. The estimated purchase volume for each item represents the approximate volume of anticipated purchases only. No future use of the Contract or any individual item is guaranteed or implied.

Vendors shall electronically enter the information into the Pricing Page through wvOASIS, if available, or as an electronic document. In most cases, Vendor can request an electronic copy of the Pricing Page for bid purposes by sending an email request to the following email address: erin.a.webb@wv.gov

Confidentiality Policies and Information Security Accountability: Vendor agrees to adhere to the Confidentiality Policies and Information Security Accountability Requirements Which can be found at: <https://www.state.wv.us/admin/purchase/privacy/> At the Agencies discretion, the Agency can require the Vendor and its employees to execute the Confidentiality Agreement.

REQUEST FOR QUOTATION

ARFQ 0608 DCR2500000020
Electric Slab Scissor Lifts for
Anthony Correctional Center and Jail

5. PAYMENT:

5.1 Payment: Vendor shall accept payment in accordance with the payment procedures of the State of West Virginia.

6. DELIVERY AND RETURN:

6.1 Shipment and Delivery: Vendor shall ship the Contract Items immediately after being awarded this Contract and receiving a purchase order or notice to proceed. Vendor shall deliver the Contract Item within 10 working days after receiving a purchase order or notice to proceed. Contract Item must be delivered to the Agency address below:

Anthony Correctional Center and Jail
313 Anthony Center Drive
White Sulphur Springs, WV 24986

6.2 Late Delivery: The Agency placing the order under this Contract must be notified in writing if the shipment of the Contract Item will be delayed for any reason. Any delay in delivery that could cause harm to an Agency will be ground for cancellation of the Contract, and/or obtaining the Contract Item from a third party.

6.3 Delivery Payment/Risk of Loss: Vendor shall deliver the Contract Item F.O.B destination to the Agency's location

6.4 Return of Unacceptable Items: If Agency deems the Contract Item to be unacceptable, the Contract Item shall be returned to Vendor at Vendor's expense and with no restocking charge. The Vendor shall either arrange for the return within five (5) days of being notified that item is unacceptable or permit the Agency to arrange for the return and reimburse Agency for delivery expenses. If the original packaging cannot be utilized for the return, Vendor will supply the Agency with appropriate return packaging upon request. All returns of unacceptable items shall be F.O.B. Agency's location. The returned product shall either be replaced, or the Agency shall receive full credit or refund for the purchase price, at Agency's discretion.

REQUEST FOR QUOTATION

ARFQ 0608 DCR250000020
Electric Slab Scissor Lifts for
Anthony Correctional Center and Jail

6.5 Return Due to Agency Error: Items ordered in error by the Agency will be returned for credit within 30 days of receipt, F.O.B. Vendor's location. Vendor shall not charge a restocking fee if returned products are in a resalable condition. Items shall be deemed to be in a resalable condition if they are unused and in the original packaging. Any restocking fee for an item not in a resalable condition shall be the lower of the Vendor's customary restocking fee or 5% of the total invoiced value of the returned item.

7 VENDOR DEFAULT:

7.1 The following shall be considered a Vendor default under this Contract.

- 7.1.1** Failure to provide Contract Item in accordance with the requirements contained herein.
- 7.1.2** Failure to comply with other specifications and requirements contained herein.
- 7.1.3** Failure to comply with any laws, rules, and ordinances applicable to the Contract Services provided under this Contract.
- 7.1.4** Failure to remedy deficient performance upon request.

7.2 The following remedies shall be available to the Agency upon default.

- 7.2.1** Immediate cancellation of the Contract.
- 7.2.2** Immediate cancellation of one or more release orders issued under this Contract.
- 7.2.3** Any other remedies available in law or equity.

REQUEST FOR QUOTATION

ARFQ 0608 DCR2500000020
Electric Slab Scissor Lifts for
Anthony Correctional Center and Jail

8 MISCELLANEOUS:

8.1 Contract Manager: During its performance of this Contract, Vendor must designate and maintain a primary contract manager responsible for overseeing Vendor's responsibilities under this Contract. The Contract manager must be available during normal business hours to address any customer service or other issues related to this Contract. Vendor should list its Contract manager and his or her contact information below.

Contract Manager:	Scott Smith
Telephone Number:	(703) 624-1206
Fax Number:	(703) 832-5777
Email Address:	Requests@Fedharmony.com

INSTRUCTIONS TO VENDORS SUBMITTING BIDS

1. REVIEW DOCUMENTS THOROUGHLY: The attached documents contain a solicitation for bids. Please read these instructions and all documents attached in their entirety. These instructions provide critical information about requirements that if overlooked could lead to disqualification of a Vendor's bid. All bids must be submitted in accordance with the provisions contained in these instructions and the Solicitation. Failure to do so may result in disqualification of Vendor's bid.

2. MANDATORY TERMS: The Solicitation may contain mandatory provisions identified by the use of the words "must," "will," and "shall." Failure to comply with a mandatory term in the Solicitation will result in bid disqualification.

2A. PREBID MEETING: The item identified below shall apply to this Solicitation.

A pre-bid meeting will not be held prior to bid opening.

A Non-Mandatory PRE-BID meeting will be held at the following place and time:

A MANDATORY PRE-BID meeting will be held at the following place and time:

All Vendors submitting a bid must attend the mandatory pre-bid meeting. Failure to attend the mandatory pre-bid meeting shall result in disqualification of the Vendor's bid. No one individual is permitted to represent more than one vendor at the pre-bid meeting. Any individual that does attempt to represent two or more vendors will be required to select one vendor to which the individual's attendance will be attributed. The vendors not selected will be deemed to have not attended the pre-bid meeting unless another individual attended on their behalf. The required attribution of attendance to a single vendor should be addressed during the pre-bid but may occur at any time deemed appropriate by the Agency.

An attendance sheet provided at the pre-bid meeting shall serve as the official document verifying attendance. Any person attending the pre-bid meeting on behalf of a Vendor must list on the attendance sheet his or her name and the name of the Vendor he or she is representing. Additionally, the person attending the pre-bid meeting should include the Vendor's E-Mail address, phone number, and Fax number on the attendance sheet. It is the Vendor's responsibility to locate the attendance sheet and provide the required information. Failure to complete the attendance sheet as required may result in disqualification of Vendor's bid.

All Vendors should arrive prior to the starting time for the pre-bid. Vendors who arrive after the starting time but prior to the end of the Prebid will be permitted to sign in but are charged with knowing all matters discussed at the Prebid.

Questions submitted at least five business days prior to a scheduled pre-bid will be discussed at the pre-bid meeting if possible. Any discussions or answers to questions at the pre-bid meeting are preliminary in nature and are non-binding. Official and binding answers to questions will be published in a written addendum to the Solicitation prior to bid opening.

3. VENDOR QUESTION DEADLINE: Vendors may submit questions relating to this Solicitation to the Agency Contact. Questions must be submitted in writing. All questions must be submitted on or before the date listed below and to the address listed below to be considered. A written response will be published in a Solicitation addendum if a response is possible and appropriate. Non-written discussions, conversations, or questions and answers regarding this Solicitation are preliminary in nature and are nonbinding.

Submitted emails should have the solicitation number in the subject line.

Question Submission Deadline:

Submit Questions to:

Email:

4. BID SUBMISSION: All bids must be submitted electronically through wvOASIS or signed and delivered by the Vendor to the Agency on or before the date and time of the bid opening. Any bid received by the Agency staff is considered to be in the possession of the Agency and will not be returned for any reason.

4A. BID SUBMISSION

A bid that is not submitted electronically through wvOASIS should contain the information listed below on the face of the envelope or the bid may be rejected by the Agency.

SEALED BID:

BUYER:

SOLICITATION NUMBER:

BID OPENING DATE:

BID OPENING TIME:

FAX NUMBER:

5. ADDENDUM ACKNOWLEDGEMENT: Changes or revisions to this Solicitation will be made by an official addendum issued by the Agency. Vendors should acknowledge receipt of all addenda issued with this Solicitation by completing an Addendum Acknowledgment Form, a copy of which is included herewith. Failure to acknowledge addenda may result in bid disqualification. The addendum acknowledgement should be submitted with the bid to expedite document processing.

6. BID FORMATTING: Vendor should type or electronically enter the information onto its bid to prevent errors in the evaluation. Failure to type or electronically enter the information may result in bid disqualification.

7. ALTERNATE MODEL OR BRAND: Unless the box below is checked, any model, brand, or specification listed in this Solicitation establishes the acceptable level of quality only and is not intended to reflect a preference for, or in any way favor, a particular brand or vendor. Vendors may bid alternates to a listed model or brand provided that the alternate is at least equal to the model or brand and complies with the required specifications. The equality of any alternate being bid shall be determined by the State at its sole discretion. Any Vendor bidding an alternate model or brand should clearly identify the alternate items in its bid and should include manufacturer's specifications, industry literature, and/or any other relevant documentation demonstrating the equality of the alternate items. Failure to provide information for alternate items may be grounds for rejection of a Vendor's bid.

This Solicitation is based upon a standardized commodity. Vendors are expected to bid the standardized commodity identified. Failure to bid the standardized commodity will result in your firm's bid being rejected.

8. EXCEPTIONS AND CLARIFICATIONS: The Solicitation contains the specifications that shall form the basis of a contractual agreement. Vendor shall clearly mark any exceptions, clarifications, or other proposed modifications in its bid. Exceptions to, clarifications of, or modifications of a requirement or term and condition of the Solicitation may result in bid disqualification.

9. REGISTRATION: Prior to Contract award, the apparent successful Vendor must be properly registered with the Agency and must have paid the \$125 fee, if applicable.

10. UNIT PRICE: Unit prices shall prevail in cases of a discrepancy in the Vendor's bid.

11. ELECTRONIC FILE ACCESS RESTRICTIONS: Vendor must ensure that its submission in wvOASIS can be accessed and viewed by the Agency staff immediately upon bid opening. The Agency will consider any file that cannot be immediately access and viewed at the time of the bid opening (such as, encrypted files, password protected files, or incompatible files) to be blank or incomplete as context requires, and therefore unacceptable. A vendor will not be permitted to unencrypt files, remove password protections, or resubmit documents after bid opening to make a file viewable if those documents are required with the bid. A Vendor may be required to provide document passwords or removed access restrictions to allow the Agency to print or electronically save documents provided that those documents are viewable by the Agency prior to obtaining the password or removing the access restriction.

12. NON-RESPONSIBLE: The Director of Administrative Services reserves the right to reject the bid of any vendor as non-responsible, when the Director determines that the vendor submitting the bid does not have the capability to fully perform or lacks the integrity and reliability to assure good-faith performance.

13. ACCEPTANCE/REJECTION: The State may accept or reject any bid in whole, or in part.

14. YOUR SUBMISSION IS A PUBLIC DOCUMENT: Vendor's entire response to the Solicitation and the resulting Contract are public documents. As public documents, they will be disclosed to the public following the bid/proposal opening or award of the contract, Freedom of Information Act in West Virginia Code §§ 29B-1-1 et seq.

DO NOT SUBMIT MATERIAL YOU CONSIDER TO BE CONFIDENTIAL, A TRADE SECRET, OR OTHERWISE NOT SUBJECT TO PUBLIC DISCLOSURE.

Submission of any bid, proposal, or other document to the Agency constitutes your explicit consent to the subsequent public disclosure of the bid, proposal, or document. The Agency will disclose any document labeled "confidential," "proprietary," "trade secret," "private," or labeled with any other claim against public disclosure of the documents, to include any "trade secrets" as defined by West Virginia Code § 47-22-1 et seq. All submissions are subject to public disclosure without notice.

GENERAL TERMS AND CONDITIONS:

1. **CONTRACTUAL AGREEMENT:** Issuance of an Award Document signed by the Agency and approved as to form by the Attorney General's office, if required, constitutes acceptance of this Contract made by and between the State of West Virginia and the Vendor. Vendor's signature on its bid signifies Vendor's agreement to be bound by and accept the terms and conditions contained in this Contract.
2. **DEFINITIONS:** As used in this Solicitation/Contract, the following terms shall have the meanings attributed to them below. Additional definitions may be found in the specifications included with this Solicitation/Contract.
 - 2.1. **"Agency" or "Agencies"** means the agency, board, commission, or other entity of the State of West Virginia that is identified on the first page of the Solicitation or any other public entity seeking to procure goods or services under this Contract.
 - 2.2. **"Bid" or "Proposal"** means the vendors submitted response to this solicitation.
 - 2.3. **"Contract"** means the binding agreement that is entered into between the State and the Vendor to provide the goods or services requested in the Solicitation.
 - 2.4. **"Director"** means the Director of the West Virginia Division of Administrative Services.
 - 2.5. **"Award Document"** means the document signed by the Agency that identifies the Vendor as the contract holder.
 - 2.6. **"Solicitation"** means the official notice of an opportunity to supply the State with goods or services.
 - 2.7. **"State"** means the State of West Virginia and/or any of its agencies, commissions, boards, etc. as context requires.
 - 2.8. **"Vendor" or "Vendors"** means any entity submitting a bid in response to the Solicitation, the entity that has been selected as the lowest responsible bidder, or the entity that has been awarded the Contract as context requires.

3. CONTRACT TERM; RENEWAL; EXTENSION: The term of this Contract shall be determined in accordance with the category that has been identified as applicable to this Contract below:

Term Contract

Initial Contract Term: This Contract becomes effective on the date indicated on the awarded contract and extends for a period of _____ year(s).

Renewal Term: This Contract may be renewed upon the mutual written consent of the Agency, and the Vendor. Any request for renewal should be delivered to the Agency thirty (30) days prior to the expiration date of the initial contract term or appropriate renewal term. A Contract renewal shall be in accordance with the terms and conditions of the original contract. Unless otherwise specified below, renewal of this Contract is limited to _____ successive one (1) year periods or multiple renewal periods of less than one year, provided that the multiple renewal periods do not exceed the total number of months available in all renewal years combined. Automatic renewal of this Contract is prohibited.

Alternate Renewal Term – This contract may be renewed for _____ successive _____ year periods or shorter periods provided that they do not exceed the total number of months contained in all available renewals. Automatic renewal of this Contract is prohibited. Renewals must be approved by the Vendor and Agency.

Delivery Order Limitations: In the event that this contract permits delivery orders, a delivery order may only be issued during the time this Contract is in effect. Any delivery order issued within one year of the expiration of this Contract shall be effective for one year from the date the delivery order is issued. No delivery order may be extended beyond one year after this Contract has expired.

Fixed Period Contract: This Contract becomes effective upon Vendor’s receipt of the notice to proceed and must be completed within _____ days.

Fixed Period Contract with Renewals: This Contract becomes effective upon Vendor’s receipt of the notice to proceed and part of the Contract more fully described in the attached specifications must be completed within _____ days. Upon completion of the work covered by the preceding sentence, the vendor agrees that maintenance, monitoring, or warranty services will be provided for _____ year(s) thereafter.

One Time Purchase: The term of this Contract shall run from the issuance of the Award Document until all of the goods contracted for have been delivered, but in no event will this Contract extend for more than one fiscal year.

Other: See attached.

4. NOTICE TO PROCEED: Vendor shall begin performance of this Contract immediately upon receiving notice to proceed unless otherwise instructed by the Agency. Unless otherwise specified, the fully executed Award Document will be considered notice to proceed.

5. **QUANTITIES:** The quantities required under this Contract shall be determined in accordance with the category that has been identified as applicable to this Contract below.

Open End Contract: Quantities listed in this Solicitation are approximations only, based on estimates supplied by the Agency. It is understood and agreed that the Contract shall cover the quantities actually ordered for delivery during the term of the Contract, whether more or less than the quantities shown.

Service: The scope of the service to be provided will be more clearly defined in the specifications included herewith.

Combined Service and Goods: The scope of the service and deliverable goods to be provided will be more clearly defined in the specifications included herewith.

One Time Purchase: This Contract is for the purchase of a set quantity of goods that are identified in the specifications included herewith. Once those items have been delivered, no additional goods may be procured under this Contract without an appropriate change order approved by the Vendor, Agency, and Attorney General's office.

6. **REQUIRED DOCUMENTS:** All of the items checked below must be provided to the Agency by the Vendor as specified below.

PERFORMANCE BOND: The apparent successful Vendor shall provide a performance bond in the amount of 100% of the contract value. The performance bond must be received by the Agency prior to Contract award.

LABOR/MATERIAL PAYMENT BOND: The apparent successful Vendor shall provide a labor/material payment bond in the amount of 100% of the Contract value. The labor/material payment bond must be received by the Agency prior to Contract award.

MAINTENANCE BOND: The apparent successful Vendor shall provide a two (2) year maintenance bond covering the roofing system. The maintenance bond must be issued and delivered to the Agency prior to Contract award.

LICENSE(S) / CERTIFICATIONS / PERMITS: In addition to anything required under the Section of the General Terms and Conditions entitled Licensing, the apparent successful Vendor shall furnish proof of the following licenses, certifications, and/or permits upon request and in a form acceptable to the State. The request may be prior to or after the contract award at the State's sole discretion.

The apparent successful Vendor shall also furnish proof of any additional licenses or certifications contained in the specifications regardless of whether or not that requirement is listed above.

7. INSURANCE: The apparent successful Vendor shall furnish proof of the insurance identified by a checkmark below and must include the State as an additional insured on each policy prior to Contract award. The insurance coverage identified below must be maintained throughout the life of this contract. Thirty (30) days prior to the expiration of the insurance policies Vendor shall provide the Agency with proof that the insurance mandated herein has been continued. Vendor must also provide Agency with immediate notice of any changes in its insurance policies, including but not limited to, policy cancelation, policy reduction, or change in insurers. The apparent successful Vendor shall also furnish proof of any additional insurance requirements contained in the specifications prior to Contract award regardless of whether or not that insurance requirement is listed in this section.

Vendor must maintain:

Commercial General Liability Insurance in at least an amount of:
_____ per occurrence.

Automobile Liability Insurance in at least an amount of: _____ per occurrence.

Professional/Malpractice/Errors and Omission Insurance in at least an amount of:
_____ per occurrence. Notwithstanding the forgoing, Vendor's are not required to list the State as an additional insured for this type of policy.

Commercial Crime and Third-Party Fidelity Insurance in an amount of:
_____ per occurrence.

Cyber Liability Insurance in the amount of: _____ per occurrence.

Builders Risk Insurance in an amount equal to 100% of the amount of the Contract.

Pollution Insurance in the amount of: _____ per occurrence.

Aircraft Liability in the amount of: _____ per occurrence.

8. WORKERS' COMPENSATION INSURANCE: The apparent successful Vendor shall comply with laws relating to workers' compensation, shall maintain workers' compensation insurance when required, and shall furnish proof of workers' compensation insurance upon request.

9. LIQUIDATED DAMAGES: This clause shall in no way be considered exclusive and shall not limit the State or Agency's right to pursue any other available remedy. Vendor shall pay liquidated damages in the amount specified below or as described in the specifications:

_____ for _____

Liquidated Damages Contained in the Specifications

10. ACCEPTANCE: Vendor's signature on its bid, or on the certification and signature page, constitutes an offer to the State that cannot be unilaterally withdrawn, signifies that the product or service proposed by vendor meets the mandatory requirements contained in the Solicitation for that product or service, unless otherwise indicated, and signifies acceptance of the terms and conditions contained in the Solicitation unless otherwise indicated.

11. PRICING: The pricing set forth herein is firm for the life of the Contract, unless specified elsewhere within this Solicitation/Contract by the State. A Vendor's inclusion of price adjustment provisions in its bid, without an express authorization from the State in the Solicitation to do so, may result in bid disqualification. Notwithstanding the foregoing, Vendor must extend any publicly advertised sale price to the State and invoice at the lower of the contract price or the publicly advertised sale price.

12. PAYMENT IN ARREARS: Payment in advance is prohibited under this Contract. Payment may only be made after the delivery and acceptance of goods or services. The Vendor shall submit invoices, in arrears.

13. PAYMENT METHODS: Vendor must accept payment by electronic funds transfer or P-Card. (The State of West Virginia's Purchasing Card program, administered under contract by a banking institution, processes payment for goods and services through state designated credit cards.)

14. ADDITIONAL FEES: Vendor is not permitted to charge additional fees or assess additional charges that were not either expressly provided for in the solicitation published by the State of West Virginia or included in the unit price or lump sum bid amount that Vendor is required by the solicitation to provide. Including such fees or charges as notes to the solicitation may result in rejection of vendor's bid. Requesting such fees or charges be paid after the contract has been awarded may result in cancellation of the contract.

15. TAXES: The Vendor shall pay any applicable sales, use, personal property or any other taxes arising out of this Contract and the transactions contemplated thereby. The State of West Virginia is exempt from federal and state taxes and will not pay or reimburse such taxes.

16. FUNDING: This Contract shall continue for the term stated herein, contingent upon funds being appropriated by the Legislature or otherwise being made available. In the event funds are not appropriated or otherwise made available, this Contract becomes void and of no effect beginning on July 1 of the fiscal year for which funding has not been appropriated or otherwise made available.

17. CANCELLATION: The State reserves the right to cancel this Contract immediately upon written notice to the vendor if the materials or workmanship supplied do not conform to the specifications contained in the Contract. The Agency may also cancel any purchase or Contract upon 30 days written notice to the Vendor.

18. TIME: Time is of the essence with regard to all matters of time and performance in this Contract.

19. APPLICABLE LAW: This Contract is governed by and interpreted under West Virginia law without giving effect to its choice of law principles. Any information provided in specification manuals, or any other source, verbal or written, which contradicts or violates the West Virginia Constitution, West Virginia Code or West Virginia Code of State Rules is void and of no effect.

19A. VENUE: All legal actions for damage brought by Vendor against the State shall be brought in the West Virginia Claims Commission. Other causes of action must be brought in the West Virginia court authorized by statute to exercise jurisdiction over it.

20. COMPLIANCE WITH LAWS: Vendor shall comply with all applicable federal, state, and local laws, regulations, and ordinances. By submitting a bid, Vendor acknowledges that it has reviewed, understands, and will comply with all applicable laws, regulations, and ordinances. Vendor shall notify all subcontractors providing commodities or services related to this Contract that as subcontractors, they too are required to comply with all applicable laws, regulations, and ordinances.

21. ARBITRATION: Any references made to arbitration contained in this Contract, Vendor's bid, or in any American Institute of Architects documents pertaining to this Contract are hereby deleted, void, and of no effect.

22. MODIFICATIONS: This writing is the parties' final expression of intent. Notwithstanding anything contained in this Contract, to the contrary, no modification of this Contract shall be binding without mutual written consent of the Agency and the Vendor.

23. WAIVER: The failure of either party to insist upon a strict performance of any of the terms or provision of this Contract, or to exercise any option, right, or remedy herein contained, shall not be construed as a waiver or a relinquishment for the future of such term, provision, option, right, or remedy, but the same shall continue in full force and effect. Any waiver must be expressly stated in writing and signed by the waiving party.

24. SUBSEQUENT FORMS: The terms and conditions contained in this Contract shall supersede any and all subsequent terms and conditions which may appear on any form documents submitted by Vendor to the Agency such as price lists, order forms, invoices, sales agreements, or maintenance agreements, and includes internet websites or other electronic documents. Acceptance or use of Vendor's forms does not constitute acceptance of the terms and conditions contained thereon.

25. ASSIGNMENT: Neither this Contract nor any monies due, or to become due hereunder, may be assigned by the Vendor without the express written consent of the Agency and any other government agency or office that may be required to approve such assignments.

26. WARRANTY: The Vendor expressly warrants that the goods and/or services covered by this Contract will: (a) conform to the specifications, drawings, samples, or other description furnished or specified by the Agency; (b) be merchantable and fit for the purpose intended; and (c) be free from defects in material and workmanship.

27. STATE EMPLOYEES: State employees are not permitted to utilize this Contract for personal use and the Vendor is prohibited from permitting or facilitating the same.

28. PRIVACY, SECURITY, AND CONFIDENTIALITY: The Vendor agrees that it will not disclose to anyone, directly or indirectly, any such personally identifiable information or other confidential information gained from the Agency, unless the individual who is the subject of the information consents to the disclosure in writing or the disclosure is made pursuant to the Agency's policies, procedures, and rules. Vendor further agrees to comply with the Confidentiality Policies and Information Security Accountability Requirements, set forth in:
<http://www.state.wv.us/admin/purchase/privacy/default.html>

28A. CONFIDENTIALITY POLICIES AND INFORMATION SECURITY

ACCOUNTABILITY: The Vendor agrees to adhere to the Confidentiality Policies and Information Accountability Requirements set forth in the link below. At the Agencies sole discretion, the Agency can require the Vendor and its employees to execute the confidentiality agreement.
<http://www.state.wv.us/admin/purchase/privacy/default.html>

29. YOUR SUBMISSION IS A PUBLIC DOCUMENT: Vendor's entire response to the Solicitation and the resulting Contract are public documents. As public documents, they will be disclosed to the public following the bid/proposal opening or award of the contract, as required by the competitive bidding laws of the State of West Virginia and the Freedom of Information Act West Virginia Code §§ 29B-1-1 et seq.

DO NOT SUBMIT MATERIAL YOU CONSIDER TO BE CONFIDENTIAL, A TRADE SECRET, OR OTHERWISE NOT SUBJECT TO PUBLIC DISCLOSURE.

Submission of any bid, proposal, or other document to the Agency constitutes your explicit consent to the subsequent public disclosure of the bid, proposal, or document. The Agency will disclose any document labeled "confidential," "proprietary," "trade secret," "private," or labeled with any other claim against public disclosure of the documents, to include any "trade secrets" as defined by West Virginia Code § 47-22-1 et seq. All submissions are subject to public disclosure without notice.

30. LICENSING: In accordance with applicable law, Vendor must be licensed and in good standing in accordance with any and all state and local laws and requirements by any state or local agency of West Virginia, including, but not limited to, the West Virginia Secretary of State's Office, the West Virginia Tax Department, West Virginia Insurance Commission, or any other state agency or political subdivision. Obligations related to political subdivisions may include, but are not limited to, business licensing, business and occupation taxes, inspection compliance, permitting, etc. Upon request, the Vendor must provide all necessary releases to obtain information to enable the Agency to verify that the Vendor is licensed and in good standing with the above entities. Vendor shall notify all subcontractors providing commodities or services related to this Contract that as subcontractors, they too are required to be licensed, in good standing, and up to date on all state and local obligations as described in this section.

31. ANTITRUST: In submitting a bid to, signing a contract with, or accepting an Award Document from any agency of the State of West Virginia, the Vendor agrees to convey, sell, assign, or transfer to the State of West Virginia all rights, title, and interest in and to all causes of action it may now or hereafter acquire under the antitrust laws of the United States and the State of West Virginia for price fixing and/or unreasonable restraints of trade relating to the particular commodities or services purchased or acquired by the State of West Virginia. Such assignment shall be made and become effective at the time the purchasing agency tenders the initial payment to Vendor.

32. VENDOR CERTIFICATIONS: By signing its bid or entering into this Contract, Vendor certifies (1) that its bid or offer was made without prior understanding, agreement, or connection with any corporation, firm, limited liability company, partnership, person or entity submitting a bid or offer for the same material, supplies, equipment or services; (2) that its bid or offer is in all respects fair and without collusion or fraud; (3) that this Contract is accepted or entered into without any prior understanding, agreement, or connection to any other entity that could be considered a violation of law; and (4) that it has reviewed this Solicitation in its entirety; understands the requirements, terms and conditions, and other information contained herein. Vendor's signature on its bid or offer also affirms that neither it nor its representatives have any interest, nor shall acquire any interest, direct or indirect, which would compromise the performance of its services hereunder. Any such interests shall be promptly presented in detail to the Agency. The individual signing this bid or offer on behalf of Vendor certifies that he or she is authorized by the Vendor to execute this bid or offer, or any documents related thereto on

Vendor's behalf: that he or she is authorized to bind the Vendor in a contractual relationship; and that, to the best of his or her knowledge, the Vendor has properly registered with any State agency that may require registration.

33. VENDOR RELATIONSHIP: The relationship of the Vendor to the State shall be that of an independent contractor and no principal-agent relationship or employer-employee relationship is contemplated or created by this Contract. The Vendor as an independent contractor is solely liable for the acts and omissions of its employees and agents. Vendor shall be responsible for selecting, supervising, and compensating any and all individuals employed pursuant to the terms of this Solicitation and resulting contract. Neither the Vendor, nor any employees or subcontractors of the Vendor, shall be deemed to be employees of the State for any purpose whatsoever. Vendor shall be exclusively responsible for payment of employees and contractors for all wages and salaries, taxes, withholding payments, penalties, fees, fringe benefits, professional liability insurance premiums, contributions to insurance and pension, or other deferred compensation plans, including but not limited to, Workers' Compensation and Social Security obligations, licensing fees, etc. and the filing of all necessary documents, forms, and returns pertinent to all of the foregoing. Vendor shall hold harmless the State and shall provide the State and Agency with a defense against any and all claims including, but not limited to, the foregoing payments, withholdings, contributions, taxes, Social Security taxes, and employer income tax returns.

34. INDEMNIFICATION: The Vendor agrees to indemnify, defend, and hold harmless the State and the Agency, their officers, and employees from and against: (1) Any claims or losses for services rendered by any subcontractor, person, or firm performing or supplying services, materials, or supplies in connection with the performance of the Contract; (2) Any claims or losses resulting to any person or entity injured or damaged by the Vendor, its officers, employees, or subcontractors by the publication, translation, reproduction, delivery, performance, use, or disposition of any data used under the Contract in a manner not authorized by the Contract, or by Federal or State statutes or regulations; and (3) Any failure of the Vendor, its officers, employees, or subcontractors to observe State and Federal laws including, but not limited to, labor and wage and hour laws.

35. NO DEBT CERTIFICATION: In accordance with West Virginia Code, the State is prohibited from awarding a contract to any bidder that owes a debt to the State or a Political subdivision of the State. By submitting a bid, or entering into a contract with the State, Vendor is affirming that (1) for construction contracts, the vendor is not in default on any monetary obligation owed to the State or a Political subdivision of the state, and (2) for all other contracts, that neither vendor nor any related party owe a debt as defined above and that neither Vendor nor any related party are in employer default as defined in the statute cited above unless the debt or employer default is permitted under the statute.

36. CONFLICT OF INTEREST: Vendor, its officers or members or employees, shall not presently have or acquire an interest, direct or indirect, which would conflict with or compromise the performance of its obligations hereunder. Vendor shall periodically inquire of its officers, members, and employees to ensure that a conflict of interest does not arise. Any conflict of interest discovered shall be promptly presented in detail to the Agency.

37. REPORTS: Vendor shall provide the Agency with the following reports identified by a checked box below:

Such reports as the Agency may request. Requested reports may include, but are not limited to, quantities purchased, agencies utilizing the contract, total contract expenditures by agency, etc.

Quarterly reports detailing the total quantity of purchases in units and dollars, along with a listing of purchases by agency. Quarterly reports should be delivered to the Agency.

38. BACKGROUND CHECK: In accordance with W. Va. Code § 15-2D-3, the State reserves the right to prohibit a service provider's employees from accessing sensitive or critical information or to be present at the Capital complex based upon results addressed from a criminal background check. The service provider is responsible for any costs associated with the fingerprint based state and federal background inquiry. Upon award the service provider shall submit a list of all persons who will be physically present and working at the Capitol complex to the Director of the Division of Protective Services for purposes of verifying compliance with this provision. The State reserves the right to prohibit a service provider's employees from accessing sensitive or critical information or to be present at the Capitol complex based upon results addressed from a criminal background check.

Service providers should contact the West Virginia Division of Protective Services by phone at (304) 558-9911 for more information.

DESIGNATED CONTACT: Vendor appoints the individual identified in this Section as the Contract Administrator and the initial point of contact for matters relating to this Contract.

(Name, Title)

(Printed Name and Title)

(Address)

(Phone Number) / (Fax Number)

(E-mail address)

CERTIFICATION AND SIGNATURE: By signing below, or submitting documentation through wvOASIS, I certify that I have reviewed this Solicitation in its entirety; that I understand the requirements, terms and conditions, and other information contained herein; that this bid, offer or proposal constitutes an offer to the State that cannot be unilaterally withdrawn; that the product or service proposed meets the mandatory requirements contained in the Solicitation for that product or service, unless otherwise stated herein; that the Vendor accepts the terms and conditions contained in the Solicitation, unless otherwise stated herein; that I am submitting this bid, offer or proposal for review and consideration; that I am authorized by the vendor to execute and submit this bid, offer, or proposal, or any documents related thereto on vendor's behalf; that I am authorized to bind the vendor in a contractual relationship; and that to the best of my knowledge, the vendor has properly registered with any State agency that may require registration.

By signing below, I further certify that I understand that this Contract is subject to the provisions of West Virginia code and rules and applicable adopted procedures; therefore, purchases and contracts violating West Virginia Code and rules are void and of no effect.

(Company)

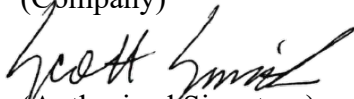

(Authorized Signature)

Representative Name, Title)

(Printed Name & Title of Authorized Representative)

(Date)

(Phone Number) (Fax Number)

ADDENDUM ACKNOWLEDGEMENT FORM

SOLICITATION NO.:

Instructions: Please acknowledge receipt of all addenda issued with this solicitation by completing this addendum acknowledgment form. Check the box next to each addendum received and sign below. Failure to acknowledge addenda may result in bid disqualification. Acknowledgment: I hereby acknowledge receipt of the following addenda and have made the necessary revisions to my proposal, plans and/or specification, etc.

Addendum Numbers Received:
(Check the box next to each addendum received)

- | | |
|----------------|-----------------|
| Addendum No. 1 | Addendum No. 6 |
| Addendum No. 2 | Addendum No. 7 |
| Addendum No. 3 | Addendum No. 8 |
| Addendum No. 4 | Addendum No. 9 |
| Addendum No. 5 | Addendum No. 10 |

I understand that failure to confirm the receipt of addenda may be cause for rejection of this bid. I further understand that any verbal representation made or assumed to be made during any oral discussion held between Vendor’s representatives and any state personnel is not binding. Only the information issued in writing and added to the specifications by an official addendum is binding.

Global Enterprise, Inc.

Company

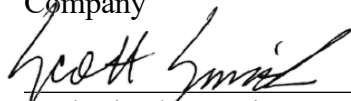

Authorized Signature

24 September 2024

Date

NOTE: This addendum acknowledgment should be submitted with the bid to expedite document processing.



**State of West Virginia
Agency Request for Quote
Miscellaneous**

Proc Folder: 1512452	Reason for Modification:
Doc Description: Genie GS-1930 Scissor Lift - Anthony Correctional Center	
Proc Type: Agency Purchase Order	

Date Issued	Solicitation Closes	Solicitation No	Version
2024-09-11	2024-09-25 10:30	ARFQ 0608 DCR2500000020	1

BID RECEIVING LOCATION

VENDOR

Vendor Customer Code:
Vendor Name : Global Enterprise, Inc.
Address :
Street : 104 Tech Park Drive, Suite 11
City : Cambridge
State : MD **Country :** USA **Zip :** 21613
Principal Contact : Scott Smith
Vendor Contact Phone: (703) 624-1206 **Extension:**

FOR INFORMATION CONTACT THE BUYER

Alyssa E Webb
 (304) 926-0499
 erin.a.webb@wv.gov

Vendor Signature X  **FEIN#** 47-4535668 **DATE** 24 September 2024

All offers subject to all terms and conditions contained in this solicitation

ADDITIONAL INFORMATION

PURPOSE AND SCOPE: The West Virginia Department of Homeland Security - Division of Administrative Services (DAS) is soliciting bids on behalf of the West Virginia Division of Corrections and Rehabilitation (DCR) for Anthony Correctional Center and Jail to establish a contract for one time purchase of one (1) Electric Slab Scissor Lift. The facility is located at 313 Anthony Center Drive, White Sulphur Springs, WV 24986.

INVOICE TO	SHIP TO
ANTHONY CORRECTIONAL CENTER 313 ANTHONY CENTER DR WHITE SULPHUR SPRINGS WV US	ANTHONY CORRECTIONAL CENTER 313 ANTHONY CENTER DR WHITE SULPHUR SPRINGS WV US

Line	Comm Ln Desc	Qty	Unit Issue	Unit Price	Total Price
1	Genie GS - 1930, e-Drive, 110 V GS1930E1CE0001 or Equal	1.00000	EA	\$14,572	\$14,572

Comm Code	Manufacturer	Specification	Model #
20102306			

Extended Description:

3.1.1.1 Vendor must provide a quantity of one (1) Genie GS - 1930, E-Drive, 110 V GS1930E1CE0001 New Lift or Equal with the following features on the Specifications Slab Scissor Lift ACC.

SCHEDULE OF EVENTS

<u>Line</u>	<u>Event</u>	<u>Event Date</u>
1	Q & A	2024-09-18

	Document Phase	Document Description	Page
DCR250000020	Final	Genie GS-1930 Scissor Lift - Anthony Correctional Center	3

**EXHIBIT A – Pricing Page
ARFQ DCR250000007
Genie GS – 1930, e-Drive, 110 V
GS1930E1CE0001 or Equal**

Section	Description	Make and Model if bidding an or Equal	Unit of Measure	Quantity	Unit Cost	Extended Cost
3.1.1	Genie GS-1930 Scissor Lift for Anthony Correctional Center as noted in 3.1.1	Genie GS – 1930, e-Drive, 110 V GS1930E1CE0001 or Equal	EA	1	\$ 14,572.00	\$ 14,572.00
					Overall Total Cost	\$ 14,572.00

Vendor must complete and return this Pricing Page.

Any product or service not on the Agency provided Pricing Page will not be allowable. The State cannot accept an alternate Pricing Page, failure to use Exhibit A Pricing Page will lead to disqualification of vendor's bid. No future use of the Contract or any individual item is guaranteed or implied. A no bid entered in the Pricing Page will result in Vendor's bid being disqualified.

Vendor should type or electronically enter the information into the Pricing Page to prevent errors in the evaluation.

BIDDER /VENDOR INFORMATION:

Vendor Name:	Global Enterprise, Inc.
Address:	104 Tech Park Drive; Suite 11
City, St. Zip:	Cambridge, MD 21613
Phone No.:	703-624-1206
Email Address:	Requests@Fedharmony.com

Vendor Signature: Scott Smith

Date: 24 Sept 2024